

BAT SONAR

By THOMAS SCARBOROUGH

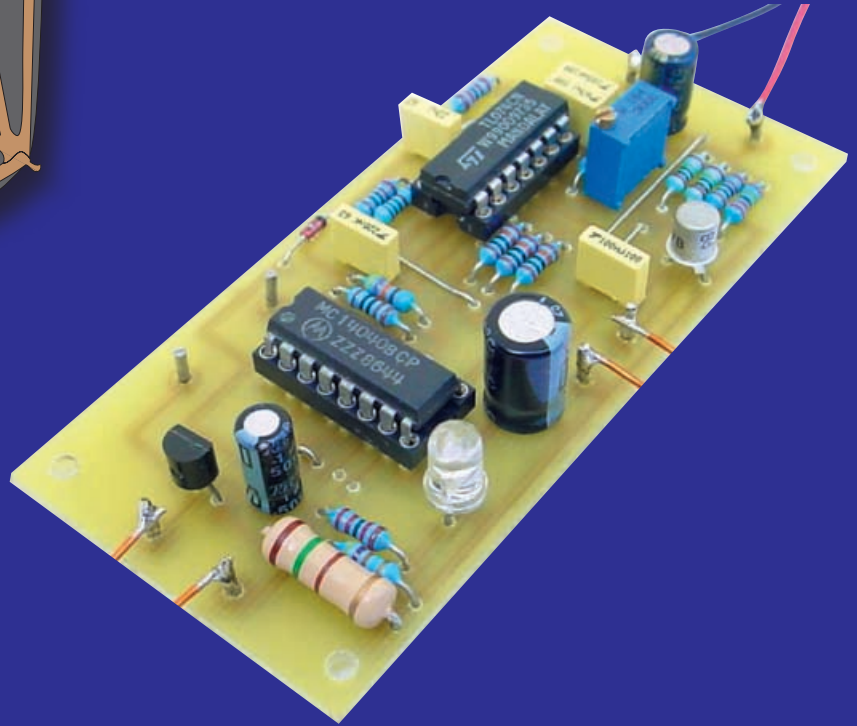
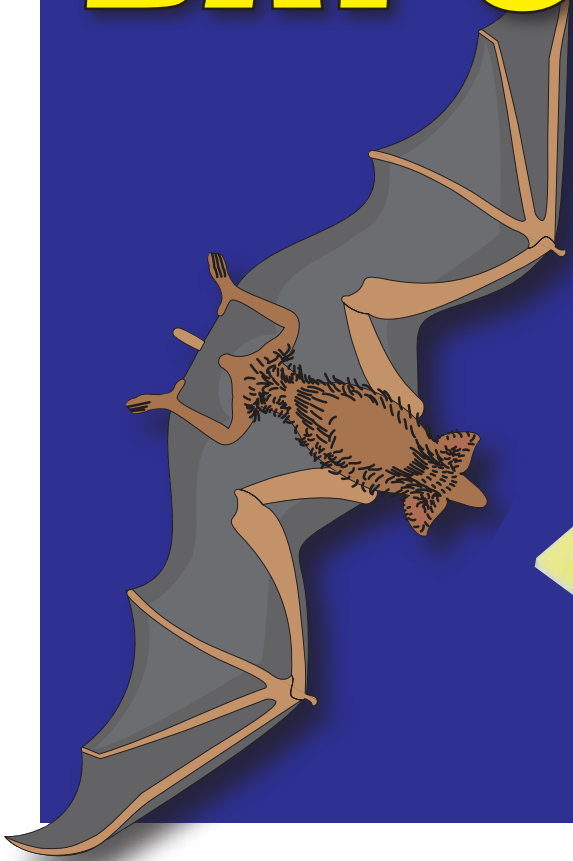

Tune into the secretive world of bats with this low-cost detector. With the addition of just a few extra components you can even create a simple sonar system

THE author was at a loss as to what to name this project. While it is in the first instance a very sensitive bat detector, it is also an ultrasonic remote control – and, with some simple surgery, may serve as a sound navigation ranging system (sonar).

Although sonar is usually associated with navigation ranging under water, it may also be used to good effect in air (for instance, to detect boats in a fog). In this case, the circuit will detect objects at a specific distance (about eight metres), while ignoring them at greater or lesser distances (e.g. 6m or 10m).

Bats typically emit bursts of ultrasound in the range of 15kHz to 200kHz, depending on the species. However, sounds above about 80kHz are rare. Some cheap piezo input devices will pick up bats at up to about 60kHz, and this is suitable for most species.

Bats are, of course, not the only creatures which emit ultrasound. The author has picked up a number of unidentified creatures with bat detectors – presumably all of them insects.

Window of sound

As a bat detector, the circuit has a number of special characteristics;

these being highlighted in the Features panel. The circuit further lends itself to converting it into a sonar system. Only a handful of additional components being required.

If one pulses a short stream of ultrasound, and opens up a ‘window’ for listening to the echo, one has a system that will detect objects at specific distances. One of the reasons why this has not been made a ‘foreground’ feature of this design is that dealing with bouncing (ultra) sound waves can be tricky, and may require a great deal of patience. However, details are included for the creation of an excellent sonar system.

Block diagram

The block diagram, shown in Fig.1, shows the simplicity of the design in concept. An extremely sensitive four-stage preamplifier (incorporating TR1 and IC1b to IC1d) amplifies the input from the piezo input device

to the point where this is capable of clocking a divider.

The divider, in this case, divides the input frequency by 16. As an example, a 40kHz signal would be divided down to an audible 2.5kHz. This is then output to a loudspeaker and/or to an LED, as desired.

The Bat Sonar includes two innovations, without which it would be a far less capable circuit:

- Op amp oscillator IC1a resets divider IC2 at about 750Hz. This means that all frequencies below 12kHz (750Hz x 16) at the IC2 clock input will be trapped by the divider, not being fast enough to outpace the reset pulses. Since 12kHz is very high in the audio range, and since 12kHz *continuous* would be required for pulses to reach the output, natural sounds are all but completely excluded.

- One further innovation is required. Supposing that divider IC2 should be clocked between 12kHz and 24kHz. In this case, only a single divided-down pulse would exit the divider for every 16 to 32 pulses received at the clock input. That is, the sound output would be completely 'flat', where the input may vary considerably in frequency.

With this in mind, as soon as a pulse is detected at the output, a feedback circuit causes oscillator IC1a (the high-pass 'filter') to be momentarily disabled. Thus the circuit is capable of reproducing nuances of sound, e.g. an ultrasonic tremolo.

Circuit details

The full circuit diagram for the Bat Sonar is shown in Fig.2. The front end of the circuit is a simple, common emitter, transistor preamplifier

SPECIAL FEATURES

- ★ The circuit is exceedingly sensitive. As an example, with its high-pass 'filter' suitably adjusted, it will pick up the ultrasound created by hands (palm-prints) rubbing together at a distance of several metres.
- ★ It is extraordinarily flexible. It may use almost any piezo input device of one's choosing; whether a 40kHz ultrasonic receiver or a cheap piezo sounder. It also offers two audio outputs (loud and soft), and a visual output.
- ★ Filtering out of low frequencies is virtually total, so you can mount an output loudspeaker and a microphone on top of each other. Not only this, but the Bat Sonar will pick up ultrasound even where there is strong background noise, for example, a piano playing in the same room.
- ★ The one small disadvantage of this design is that the sound output is a square wave. Thus, the Bat Sonar has a harsher sound than some bat detectors, and a constant volume.

(TR1). The base (b) of TR1 is biased through resistor R1. Transistor TR1 is a.c. coupled to a three-stage op amp preamplifier IC1b to IC1d, with the first stage being biased at the input through resistors R3 and R4. The gain of the first stage IC1b is adjusted through multitrurn preset VR1. Typically, a mid-way setting will usually be found suitable.

The piezo input device (X1) may be any one of a range of devices: for example, a cheap piezo sounder; a 40kHz ultrasonic receiver; a small piezo cone tweeter; or a piezo speaker. The device which was found to perform best (better, in fact, than a 40kHz ultrasonic receiver) was a small piezo cone tweeter. This was found to work at up to about 60kHz. The least suitable devices are cheap piezo sounders,

chiefly for the reason that they generate too much noise. They are capable of working up to about 40kHz.

The amplified signal at the output of preamplifier IC1b to IC1d then clocks divider IC2, a CMOS 12-stage ripple counter. The output (divided by 16) is taken from output Q4 (pin 5) of IC2.

Op amp relaxation oscillator IC1a sends short pulses to IC2's Reset pin 11, resetting IC2 at about 750Hz, and cancelling all input pulses below 12kHz – as described earlier. For this reason, no standard filters are included in the circuit – they are not required.

It needs to be borne in mind that in order for a 12kHz signal to exit the divider (IC2), this needs to be 12kHz *continuous*. This means that erratic ultrasound needs to be

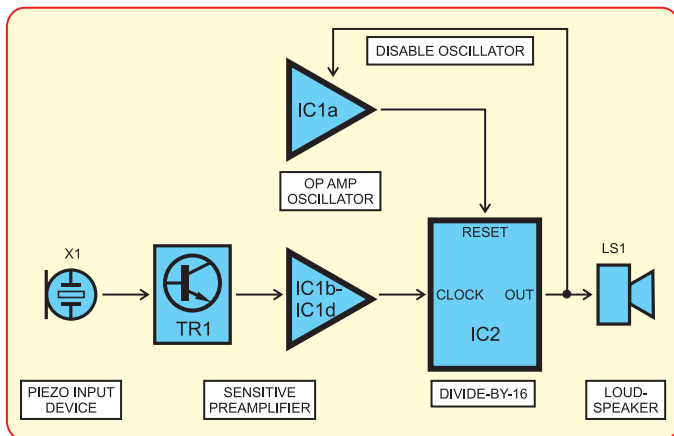

Fig.1. Basic block diagram for the Bat Sonar



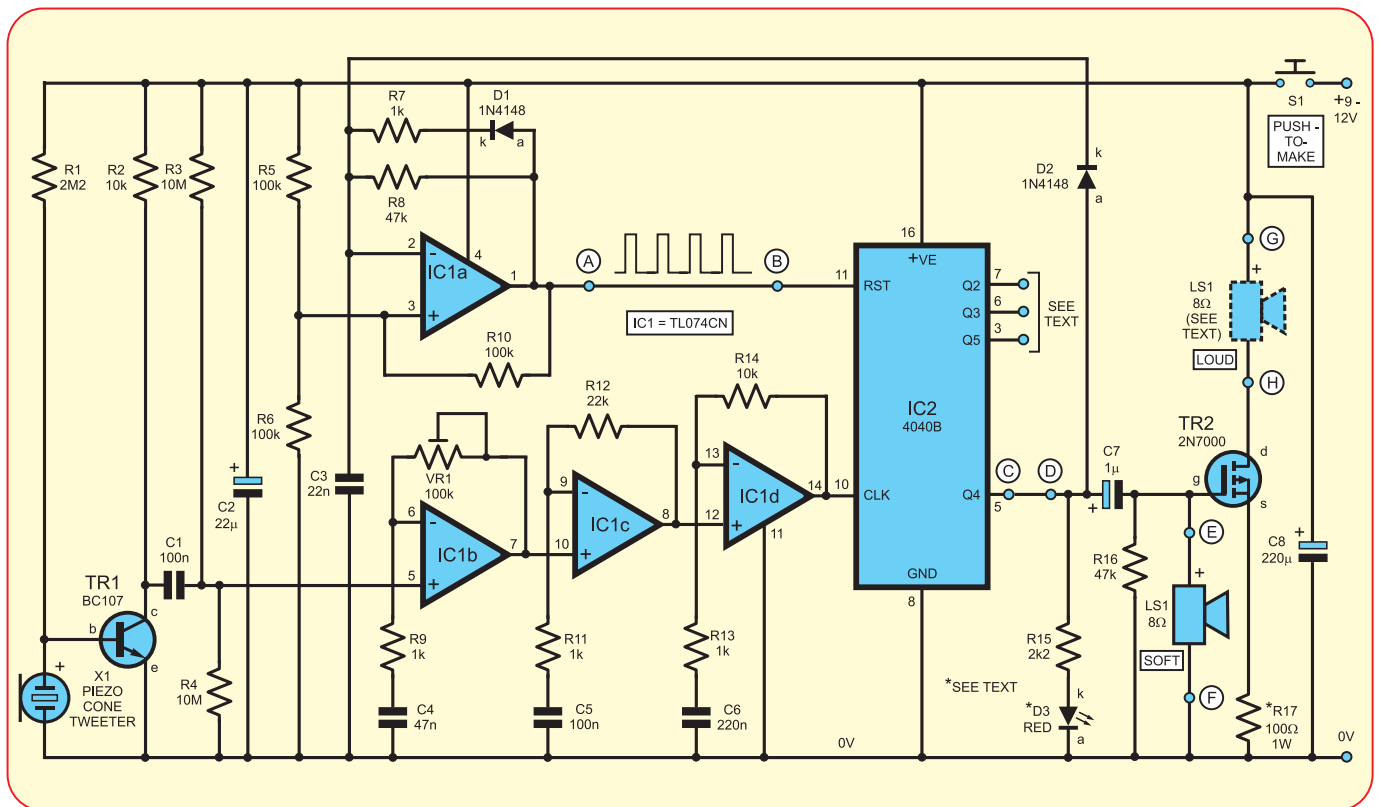

Fig.2. Complete circuit diagram for the Bat Sonar. The circled points on the circuit enable ‘variations on a theme’ to be undertaken as discussed in the text

somewhat higher than 12kHz to be detected. You can experiment with the frequency of oscillator IC1a by altering the values of resistor R8 and capacitor C3. A lower frequency (i.e. higher values for R8 and C3) would cause the circuit to hear near-ultrasound or random ultrasound, e.g. the crinkling of plastic.

Finally, IC2’s output is taken to a small loudspeaker (LS1). There is effectively no feedback, so the speaker may be mounted close to the piezo input device. A loudspeaker *must* be used here, and not a piezo tweeter. LED D3 may be used with or without a loudspeaker, and provides a visual indication of ultrasound. This could be very useful if you should not wish to disturb animals or insects being listened to.

Two circuit options are provided for a loudspeaker. The output may be taken directly from points E and F, and this is recommended. Alternatively, it may be taken, much amplified by FET TR2, from points G and H. However, there may then be a slight loss of sensitivity to the circuit. This latter option is not only for the benefit of noise-freaks – it is also capable of switching a relay (see below).

Remote control

The circuit is very easily converted to a remote control system. Due to its complete elimination of lower frequencies, it could, for example, be used to open a garage door, without one needing to be concerned about the system being triggered by dogs barking or cars hooting etc.

In this case, resistor R17 is replaced with a link wire, and the dashed speaker LS1 with a relay. The relay coil being connected between points G and H on the circuit. An electrolytic capacitor is wired across points E and F, observing the correct polarity – and the value of resistor R16 is raised to perhaps 1MΩ. Capacitor C7 is replaced with a 1N4148 diode, with its cathode (k) pointing to TR2’s gate (g).

In this way, R16 and the added capacitor serve as a simple timer. The timing period will be a little less than $t = CR$. For example, a 1MΩ value for R16 and 100μF for the added capacitor would switch the relay for more than a minute. The relay should have a coil resistance greater than 60 ohms.

An ultrasonic oscillator (the transmitter) is, of course, required to trigger such a circuit. This may be virtually

any simple oscillator tuned to an ultrasonic frequency, using a suitable output device, e.g. a piezo tweeter. Datasheets for the 555 timer or the CMOS 4047B multivibrator include such simple circuits, as well as the equations to calculate the output frequency.

Note that the Bat Sonar may not only be used as a remote control, but with simple modifications to the input, it may be used to switch when, for example, machinery runs too fast or too slow.

Sonar system

The Bat Sonar may be converted to a sonar system with remarkable ease (see Fig.3.). This is accomplished by simply inserting the add-on circuit of Fig.3 between points A and B (IC1a pin1 and IC2 pin11) of the main circuit (Fig.2.).

This switches an ultrasonic oscillator, then waits several milliseconds before opening up a ‘window’ to listen for the return stream of ultrasound. If the distance to the object being detected is correct, the ultrasound will enter the ‘window’ and the circuit will trigger. The remote control circuit described above may be used to switch a relay.

Note that this is not a silent circuit. In theory, it would seem to be – however, the switching of the ultrasonic transmitter causes the output device to emit sound at the frequency at which it is switched. Alternatively

IC3 output 1 (pin 2) enables an ultrasonic oscillator. A standard 555 astable oscillator would suffice for a few metres' range, with its Reset (pin 4) being used to enable the oscillator. It is suggested that the ultrasonic oscillator should have a separate power supply, with the 0V rail of both circuits being commoned.

At present, if (as suggested) IC3 is switched at about 750Hz, and IC3 cycles through nine stages before opening up a 'window' to receive the return stream, one has a delay of 12ms between transmission and reception. Since sound travels at about 330 metres per second, this is about four metres return, or two metres to the target. The calculation is $330 \text{ metres per second} / 750\text{Hz} \times 9 \text{ stages} = 3.96 \text{ metres return}$.

The frequency of oscillator IC1a may be lowered to extend the range of the sonar system, and different output pins (Q2 to Q5) may be tried to widen or narrow the 'window' which receives return pulses.

If the frequency of IC1a is halved, and IC2 output Q4 (pin 5) is used, this should be suitable for a range of 8m return – assuming that the ultrasonic oscillator (the transmitter) has sufficient volume. For 16 metres return, the frequency of IC1a would be halved again, and output Q5 (pin 3) may be tried.

Needless to say, the frequency of the ultrasonic oscillator will also come

There is almost no limit to the power of the ultrasonic oscillator. For instance, a power amplifier wired as a relaxation oscillator, together with a piezo speaker, could achieve a considerable range – as much as tens of metres.

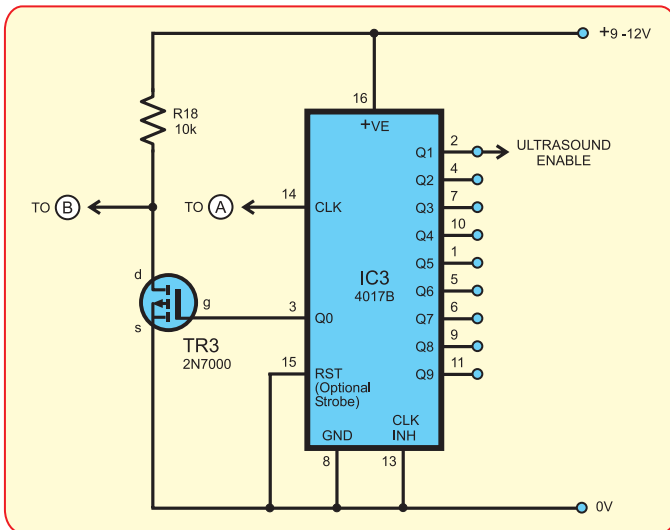

Fig.3. Add-on circuit for converting to a sound sonar system

(see below) it may emit a click every time it is strobed.

While the author successfully tested the circuit shown in Fig. 3, when tried in his workroom, it was found that the ultrasound may bounce all around the room. Ideally, the sonar would be used to detect objects blocking a clear path, e.g. boats on the water, or cars on the road. The author would suggest setting up the circuit on a clear surface with a single wall in front of one, e.g. a wall on a tennis court.

One may further need to adjust the sensitivity of the circuit, calculate the required period of bounce, and balance the frequency of ultrasonic transmission against the number of return pulses required to trigger the circuit.

At any rate, as a start, you can easily wire up the circuit shown, and go from there. Suitable holes are provided on the printed circuit board (PCB) to make this 'a snap'. It is suggested that, instead of taking the output from IC2 output Q4 as shown in Fig. 2, this should be taken from output Q3 (Q2 and Q5 are also provided for experimentation). Output Q3 requires only eight pulses at IC2's clock input instead of sixteen, thus making reception of the return pulse less tricky. Note that the circuit board link between points A and B is omitted when IC3 is inserted into the circuit.

Parts List – Bat Sonar

- 1 PC board, code 621, available from the *EPE PCB Service*, size 90mm x 42mm
- 1 plastic case, size and type to individual choice
- 1 piezoelectric input device (preferably a small cone tweeter – see text) (X1)
- 1 100kΩ cermet preset – top adjust (VR1)
- 1 miniature loudspeaker – see text (LS1)
- 1 pushbutton switch, push-to-make (S1)
- 1 9V or 12V battery, with clips (see text)
- 1 14-pin DIL socket (IC1)
- 1 16-pin DIL socket (IC2)

Solder pins (8 off); plastic covered, single-core link wire; multistrand connecting wire; solder etc.

Semiconductors

- 2 1N4148 signal diodes (D1, D2)
- 1 5mm or 3mm red ultra-bright LED (D3)
- 1 BC107B *npn* transistor (TR1)
- 1 2N7000 *n*-channel FET (TR2)
- 1 TL074CN quad FET op amp (IC1)

- 1 4040B CMOS 12-stage ripple counter (IC2)
- 1 4017B decade counter (optional, see Fig.3.) (IC3)
- 1 2N700 *n*-channel FET (optional, see Fig.3.) (TR3)

Capacitors

- 1 22nF polyester or ceramic (C3)
- 1 47nF polyester or ceramic (C4)
- 2 100nF polyester or ceramic (C1, C5)
- 1 220nF polyester or ceramic (C6)
- 1 1μF radial elect. 16V (C7)
- 1 22μF radial elect. 16V (C2)
- 1 220μF radial elect. 16V (C8)

Resistors (0.25W 5% carbon, except R17)

- 2 10MΩ (R3, R4)
- 1 2M2 (R1)
- 3 100kΩ (R5, R6, R10)
- 2 47kΩ (R8, R16)
- 1 22kΩ (R12)
- 2 10kΩ (R2, R14)
- 1 2k2 (R15)
- 4 1kΩ (R7, R9, R11, R13)
- 1 100Ω 1W (or >68Ω – see text) (R17)
- 1 10kΩ (optional, see Fig.3.) (R18)

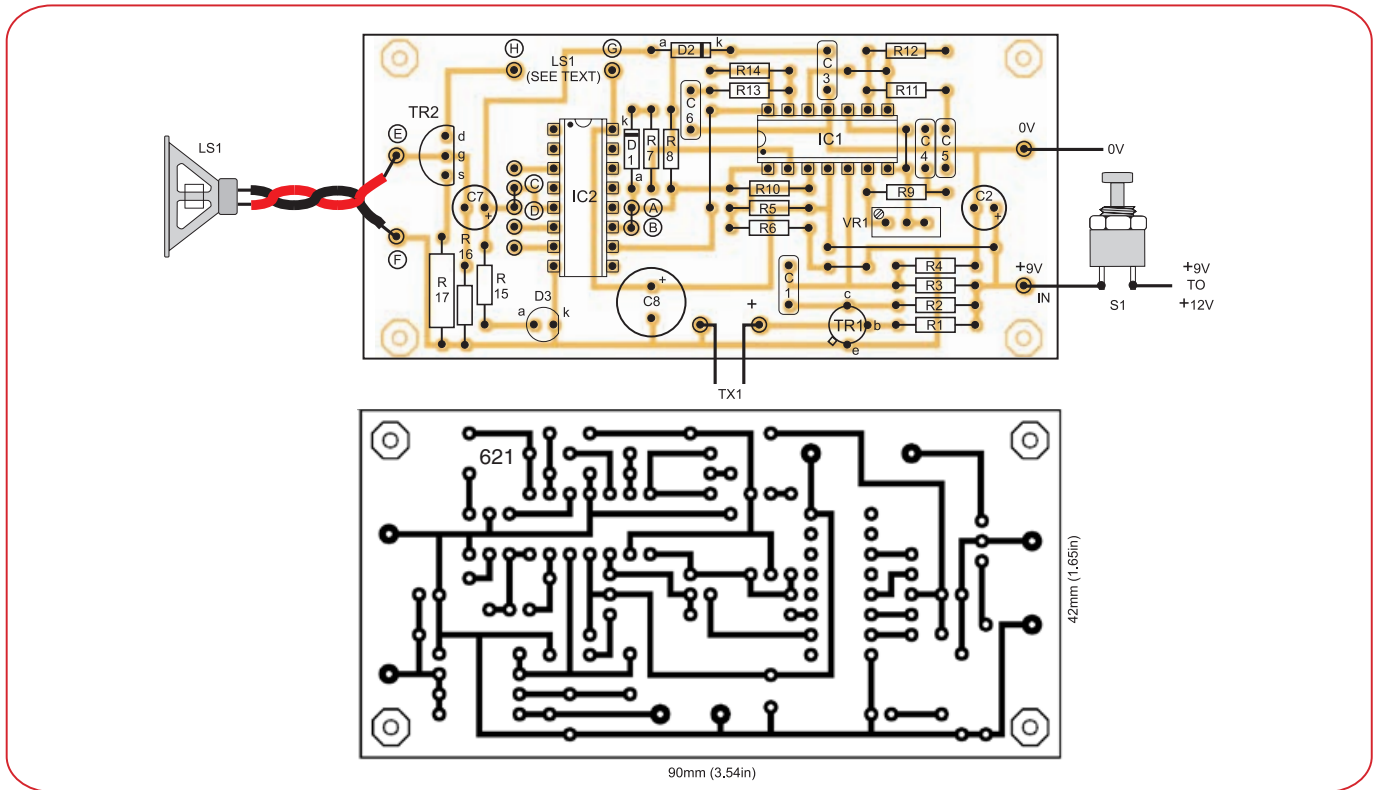

Fig.4. Bat Sonar printed circuit board component layout, wiring details and full-size underside copper foil master

into play. The lower its frequency, the fewer pulses there are to clock IC2. A signal of around 15kHz was used in the author's experiments.

In this form, as described, the Bat Sonar may be a noisy animal, emitting a 750Hz drone as it pulses the ultrasonic transmitter. There is a possibility for greatly improving this by strobing IC3 at reset pin 15. This being the case, the circuit would only send out a pulse as often as required. For instance, it could send out a click (a stream of ultrasound) only once every so many seconds – bearing in mind that its response to moving objects may no longer be immediate.

Construction

The printed circuit board (PCB) measures 90mm x 42mm (3.50in x 1.66in) and is available from the *EPE PCB Service*, code 621. Since IC2 is a CMOS device, dual-in-line (DIL) sockets are used, and anti-static precautions are advised for IC2 (in particular, discharge your body to earth before handling this IC).

It needs to be noted that IC1 is used here as a sensitive preamplifier, therefore any *unsound* solder joints may disrupt its operation far more easily than would normally be the case. Any

trouble-shooting should put this possibility high on the list.

Referring to Fig. 4, begin construction by soldering in position the six link wires. Solder the eight solder pins, and the two DIL sockets – observing the correct orientation of the sockets. Continue with the resistors and capacitors – noting the polarity of the electrolytic capacitors – and preset VR1. Note that VR1 may be replaced with a 100kΩ, front panel mounting, rotary potentiometer if desired, with a little loss of precision.

Solder in position diodes D1, D2, LED D3 and transistors TR1 and TR2, noting their polarities. Finally, solder the battery clip to its solder pins, inserting a push-to-make pushbutton switch in the positive wire as shown – being careful again to observe correct battery polarity. A mistake here could destroy the circuit. Solder the piezo pickup device X1 to its solder pins (polarity is not crucial here), and if desired, a loudspeaker either to solder pins E and F, or G and H (again, polarity is not crucial).

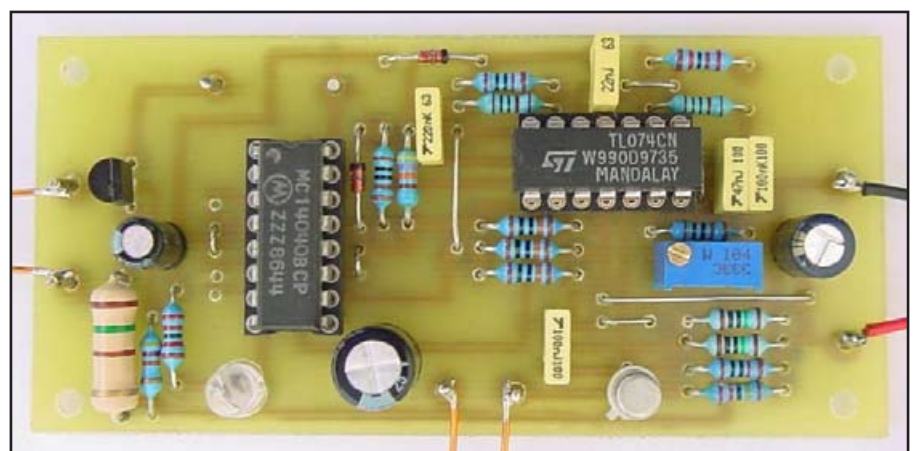

Fig.4. Components mounted on the completed 'bat board'

Bats found in Britain and Ireland

Bat type	Abundance	Region	Wingspan (cm)	Body (cm)
GREATER HORSESHOE	Scarce	SW England	34	6.4
LESSER HORSESHOE	Common	Wales, SW England, W. Eire	25	4
PIPISTRELLE	Abundant & Widespread	All Eng, Scotland, Wales, Eire & NI	22	3.5
NOCTULE	Common	All Eng (except for north). All Wales	36	7.5
LEISLERS	Rare	Central England	30	3.5
SEROTINE	Common	S & E England up to Midlands	36	6.4
COMMON LONG-EARED	Abundant & Widespread	All Eng, Wales & Scot (Except northern areas). All Eire & NI	25	4.5
NATTERER'S	Common	All Eng & Wales, SW Scot. All Eire & NI	28	4.5
BARBASTRELLE	Uncommon	SE & mid England, S Wales	27	4.5
MOUSE-EARED	Rare (Extinct?)	Sussex, Dorset	40	7
BECHSTEIN'S	Very rare	Dorset	28	4.5
WHISKERED	Common	All Eng, Wales, S. Scot	24	4
DAUBENTON'S	Widespread	All Eng, Wales. Most Scot, Eire-except SW	25	4.5

Note that some ultra-bright LEDs may confuse as to their polarity. The most reliable indicator is the 'flat' on

the side of the plastic encapsulation, which is on the side of the cathode (k) pin.

Insert IC1 and IC2 in their DIL sockets, ensuring that they are inserted the right way round – again observing anti-static precautions for IC2.

In use

Press pushbutton S1 to turn on the circuit. Red LED D3 may or may not illuminate. If it does not illuminate, turn preset VR1 clockwise – alternatively, turn VR1 anti-clockwise.

Adjust multiturn preset VR1 until there is only intermittent pulsing of LED D3, or intermittent crackling in the loudspeaker. At this point, the circuit is set to its maximum sensitivity. Such sensitivity may, however, not be required or even desirable – for example, if the Bat Sonar should be used as a remote control system.

The sensitivity of the circuit can drift a little as battery power wanes. Therefore, to use the circuit continuously at maximum sensitivity, you might wish to drill a hole in the case for the adjustment of multiturn preset VR1 – or use a potentiometer mounted on the case. **EPE**

Laser  *Why tolerate when you can automate?*

X-10 Home Automation

KAT5 KAT5 AV transmission and IR control system

BARIX Barix Ethernet based MP3, communications and control systems

www.laser.com

Integrators, Installers, Trade and Retail customers welcome

C-Bus Shop
C-Bus and C-Bus Wireless

www.cbus-shop.com

Laser Business Systems Ltd
Tel: +44 (0) 20 8441 9788
Fax: +44 (0) 20 8449 0430
Email: info@laser.com
16 Garthland Drive, EN5 3BB

www.Mechatronics-online.co.uk
Mechanical and Electronic Components

Suppliers of Mechanical and Electronic Components to the hobbyist, student and professional.

Screws
Nuts
Washers
Aluminium Sheet
Rod
Pvc Sheet
Gears
Spacers
Resistor Kits
Capacitor Kits
Transistors
Integrated circuits
Microprocessor boards
Electronic kits
Motors
Servos
Electronic Tools
Light Engineers Tools
Prototyping
Batteries

Robotics and Mechatronics



Visit our website
Mechatronics-online.co.uk
Sales@mechatronics-online.co.uk
Tel: 01442 247040

MAGENTA

ELECTRONICS LTD

135 Hunter Street Burton on Trent Staffs DE14 2ST
Tel: 44 (0)1283 565435 Fax: 44 (0)1283 546932

Chips, Parts & Kits for EPE Projects

Programmed PICs and chips for most EPE projects.
Check our website or 'phone for prices.
We have supplied kits for EPE* projects for almost 30 years!!
(* Everyday Electronics)

20W Stereo Amp.

Wide band Low distortion 11W /channel Stereo 20W Mono. True (rms) Real Power

Short Circuit & Overheat Protected. Needs 8 to 18V supply.
(Kit: inc. all parts & heatsink for stereo or mono)

KIT 914- £11.90

Latest Technology - Stable, Reliable, high performance

Top Kits.

ICEbreaker PIC16F877 in - circuit emulator - Kit 900.... £34.99

1kV/500V Insulation Tester Inc. drilled case -Kit 848.. £32.95

Pipe Descaler - High Power with led monitor - Kit 868..£22.95

Ultrasonic PEsT Scarer random 32k pulses Kit867..£19.99

P-I Metal Detector Micro based design - sensitive Kit847..£63.95

MAGENTA Bat Detectors
Our original famous KIT detector KIT 861...£37.99 & See the new built MkIIb and MKIII on the web.

All Prices Include VAT, Add £3.00 P&P per order, or £7.99 for next day. Chqs. P.O. & most major cards accepted. Mail Order Only.

MAGENTA

www.magenta2000.co.uk
sales@magenta2000.co.uk